



A broad and  
sustainable vision

| GOVAWALL<sup>®</sup>

- NL** Plaatsingsvoorschriften Govawall<sup>®</sup>
- F** Instructions de montage Govawall<sup>®</sup>
- D** Verlegeanleitung Govawall<sup>®</sup>
- UK** Installation instructions Govawall<sup>®</sup>

Download de meest recente versie op [www.govaplast.com](http://www.govaplast.com)  
Téléchargez la version la plus récente sur [www.govaplast.com](http://www.govaplast.com)  
Downloaden Sie die neueste Version von [www.govaplast.com](http://www.govaplast.com)  
Download the most recent version from [www.govaplast.com](http://www.govaplast.com)

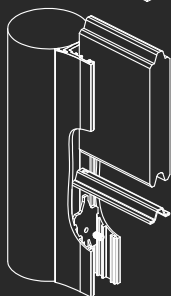
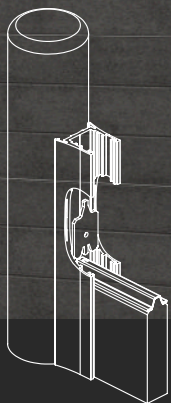

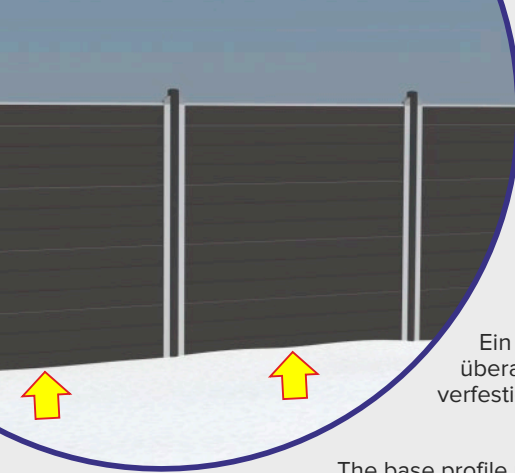

Het onderste profiel moet volledig ondersteund zijn door een stabiele ondergrond, die niet kan verzakken. (bv zandcement).

Le profilé inférieur se pose sur un sol stable, qui ne risque pas de s'affaisser, de façon que le profilé est complètement supporté. (p.e. sable-ciment)

Ein stabiler Untergrund, der sich nicht senken kann, soll überall das untere Profil unterstützen. (z.B. mit Zement verfestigter Sand)

The base profile must be placed firmly on the ground. It's important the ground can't subside. (e.g. sand-cement)

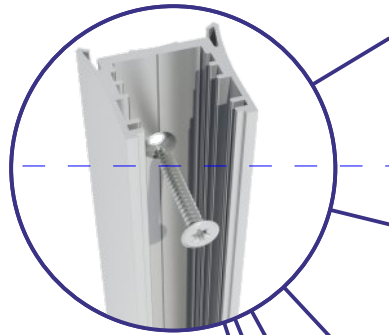
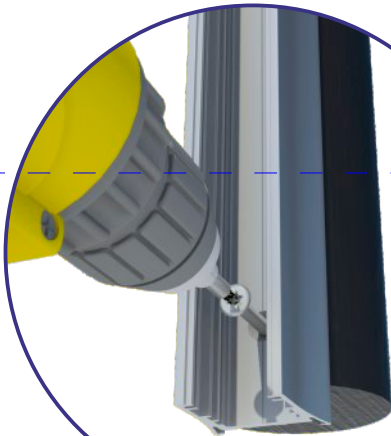

6 x Ø 6 mm



gova-screw, Torx 25

90 mm

**Govascrew**

voorboren 4 mm  
 pré-percer 4 mm  
 vorbohren 4 mm  
 pre-drill 4 mm



max 70°

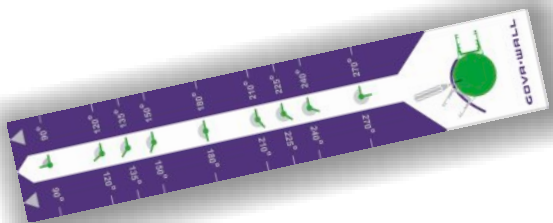
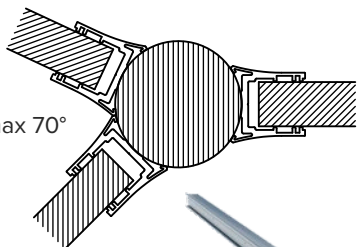

**GOVA**®home+  
**PLAST**

180°

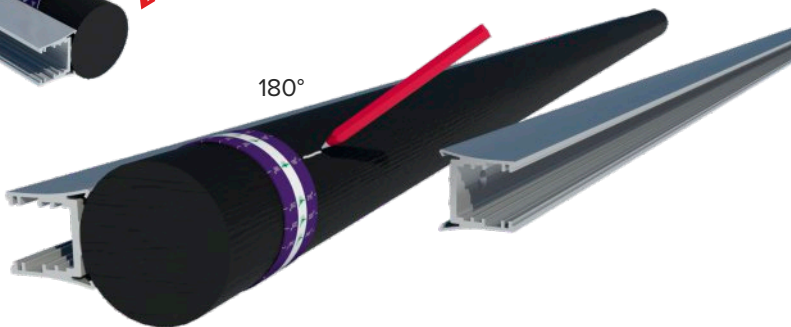

Elke paal, ook elke begin- en eindpaal moet voorzien zijn van 2 U-profielen (1 U-profiel indien bevestigd tegen een muur).

Chaque piquet, aussi le premier et le dernier, doit être pourvu de deux profilés U (1 profilé U si fixé contre un mur).

Jeder Pfosten, auch der erster und letzter, muss mit zwei U Profilen ausgestattet werden (1 U Profil falls gegen einen Wand befestigt).

Each post, also the first and the last one, must be equipped with two U-profiles (only 1 U-profile, if fixed to a wall)

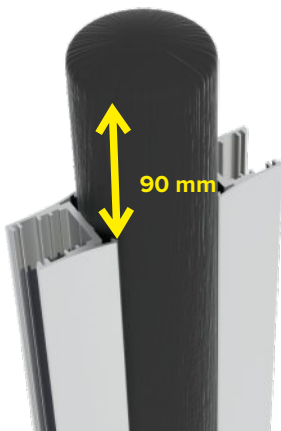
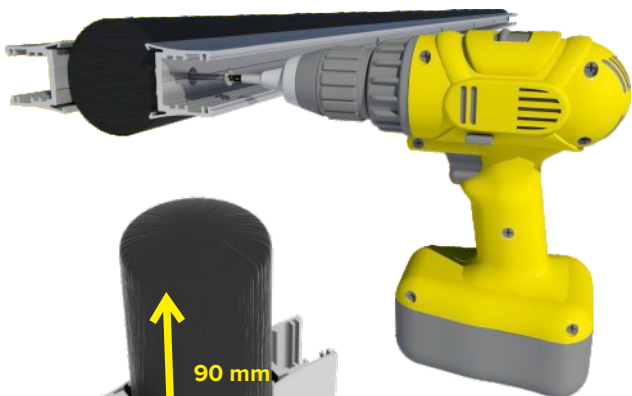

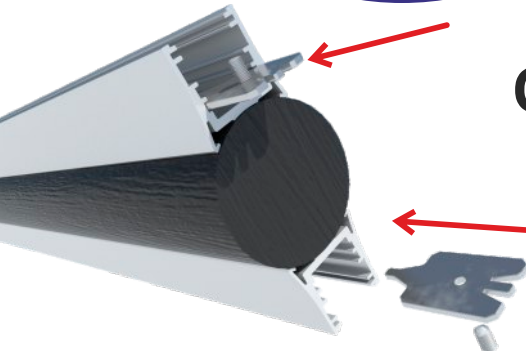
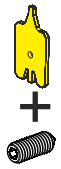
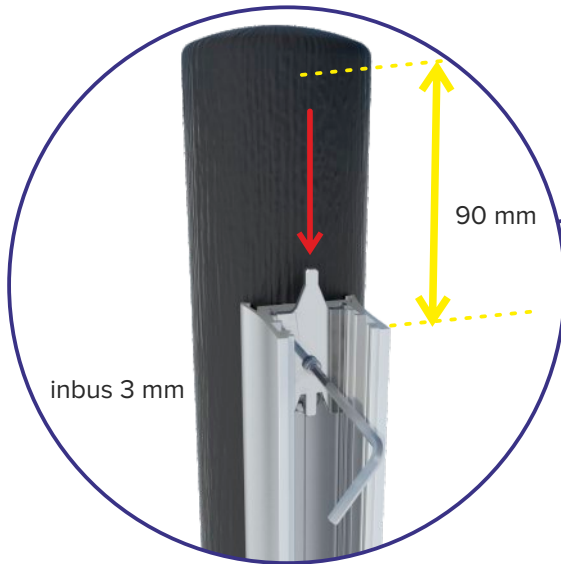

GOVA<sup>®</sup>home+  
PLAST

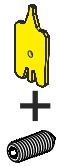
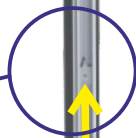
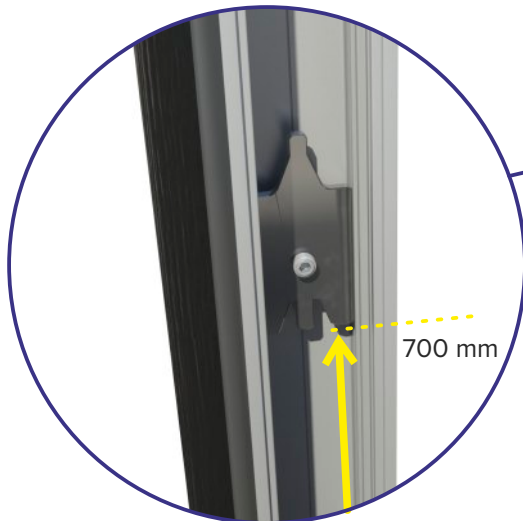

700 mm

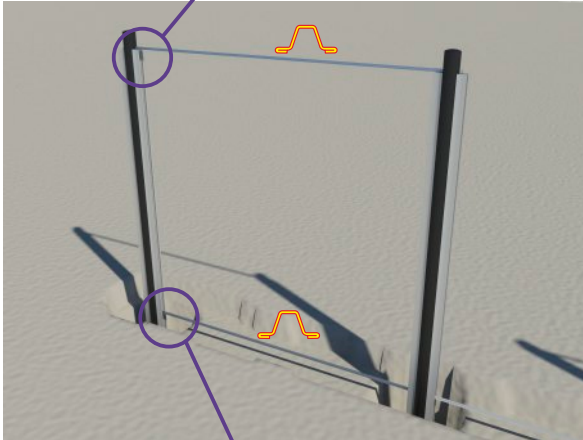
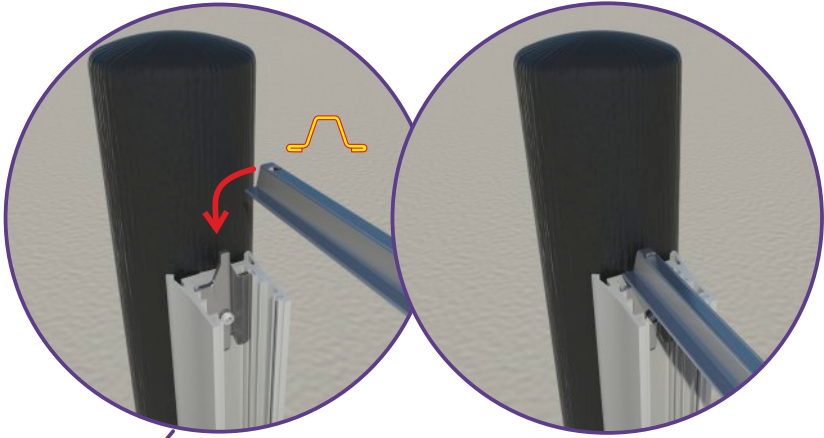

Versterkingsprofiel onder en boven voor correcte afstand tussen 2 palen.

Profilé de renforcement en haut et en bas pour distance correcte entre 2 piquets.

Verstärkungsprofil oben und unten für den genaue Abstand zwischen 2 Pfosten.

Top and bottom fortification profile for the correct distance between 2 posts.

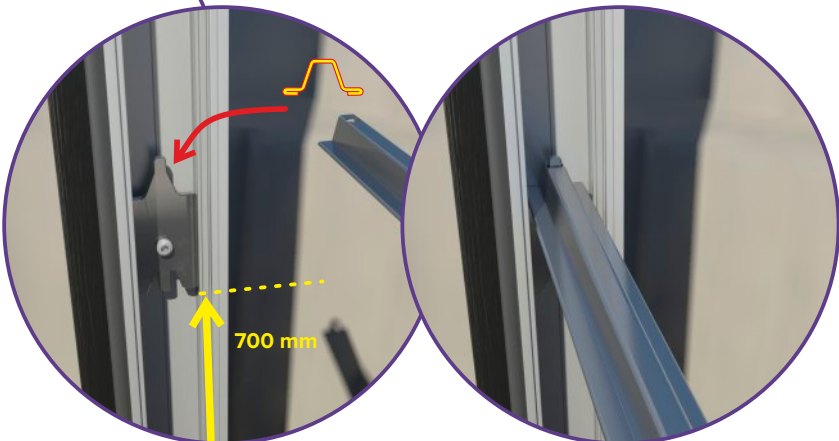

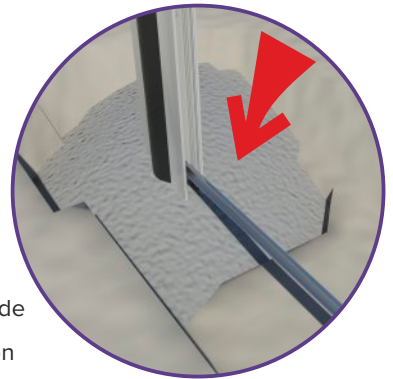
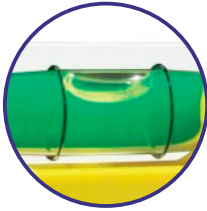
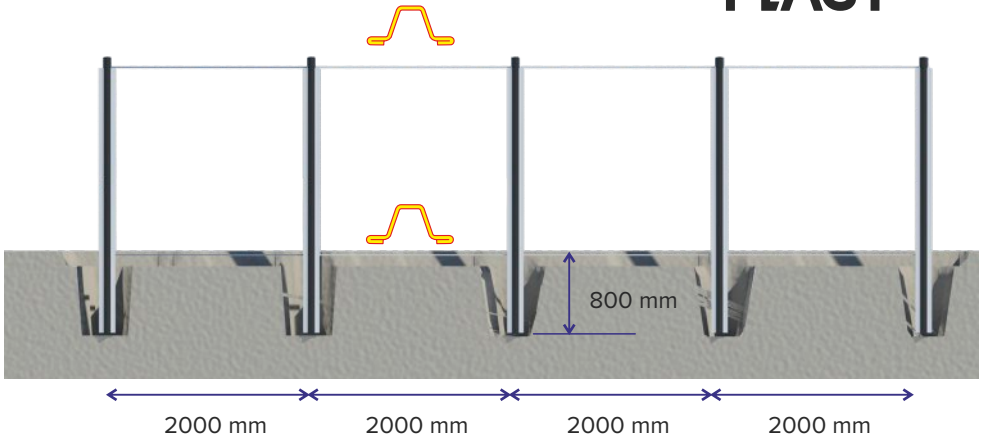

Laatste controle met waterpas + vullen met snelbeton  
Dernier contrôle avec niveau + remplir avec du béton rapide  
Letzte Kontrolle mit Wasserwaage + füllen mit Schnellbeton  
Final check with level + fill with fast setting concrete

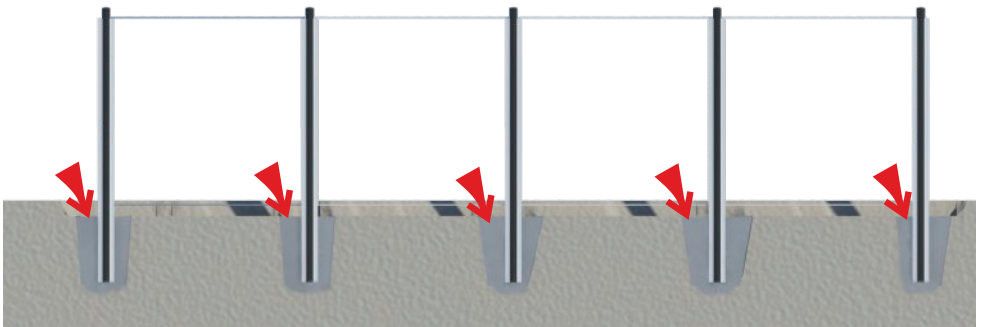

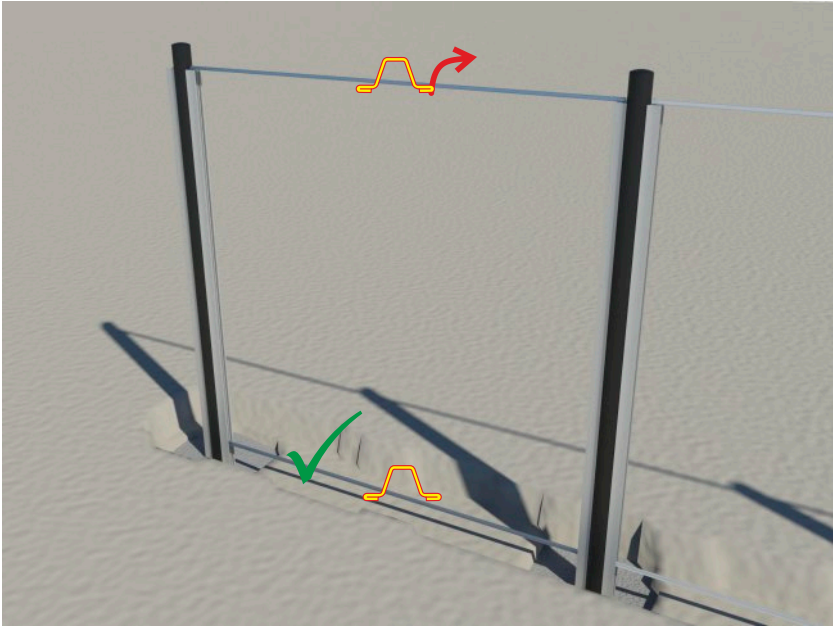

Na uitharden beton, bovenste verstergingsprofiel + govaclips verwijderen (niet onderste).

Après séchage du béton, enlever le profilé de renforcement supérieur + govaclips (pas inférieur).

Nach Trocknen des Betons, oberer Verstärkungsprofil + govaclips entfernen (nicht unterster).

When the concrete is dry, remove the top fortification profile + govaclips (not the bottom).

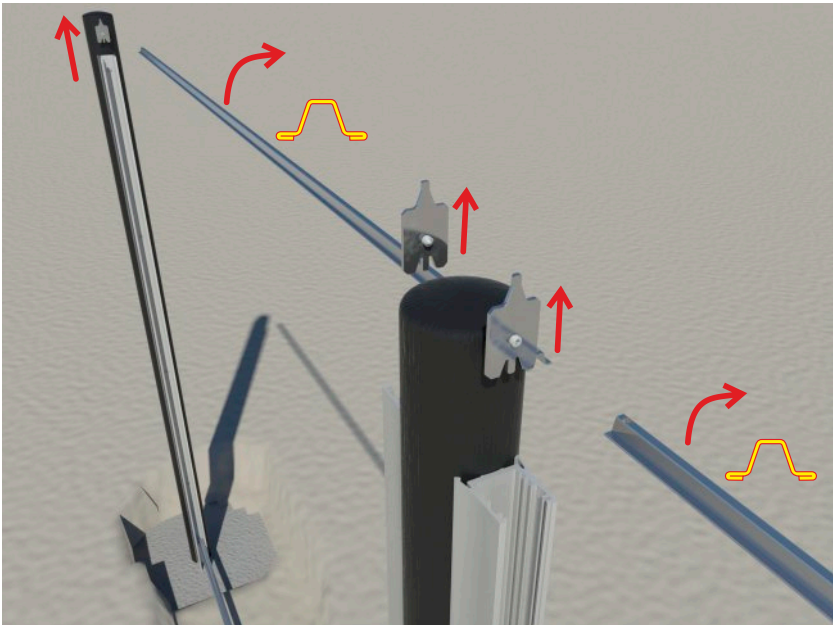

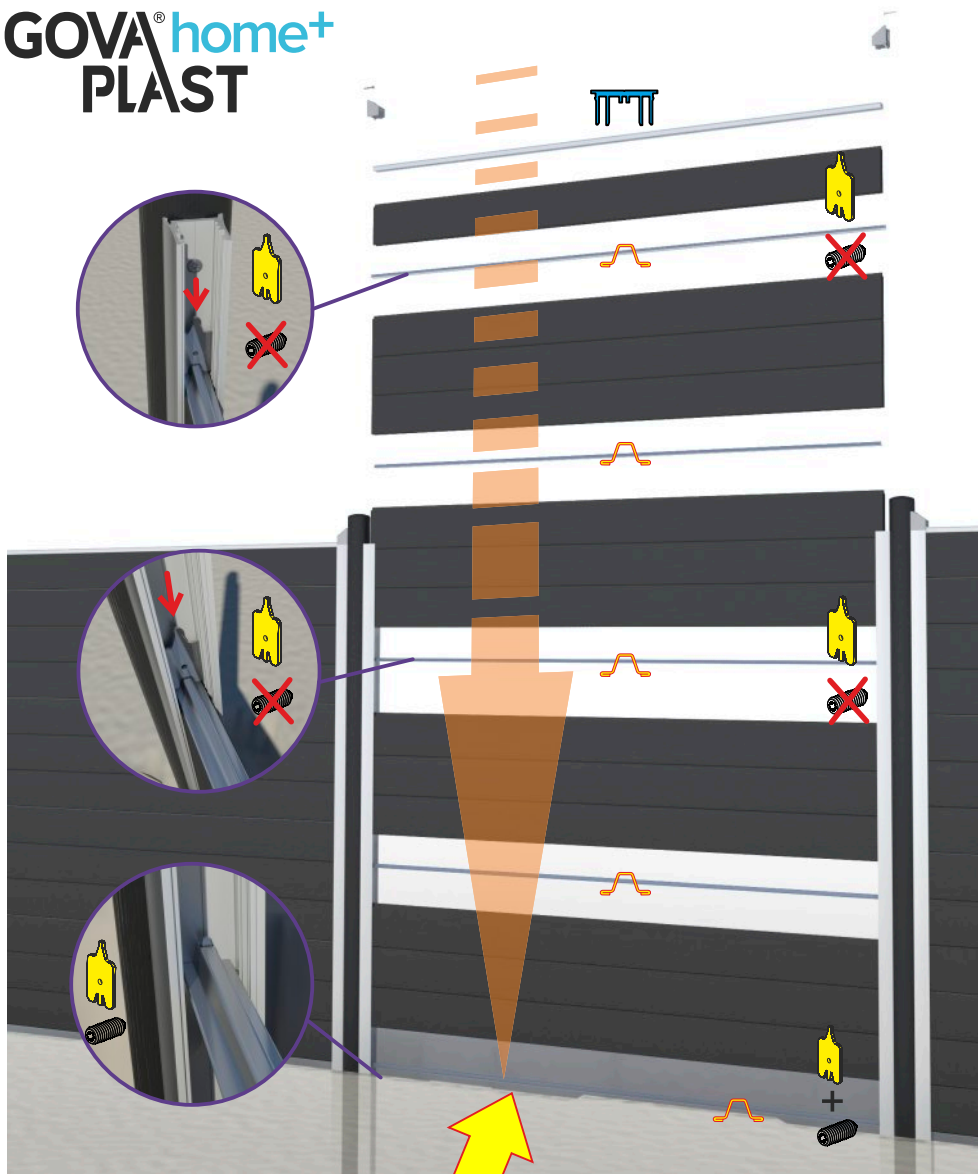

Het onderste profiel moet volledig ondersteund zijn door een stabiele ondergrond, die niet kan verzakken. (bv zandcement).

Le profilé inférieur se pose sur un sol stable, qui ne risque pas de s'affaisser, de façon que le profilé est complètement supporté. (p.e. sable-ciment)

Ein stabiler Untergrund, der sich nicht senken kann, soll überall das untere Profil unterstützen. (z.B. mit Zement verfestiger Sand)



The base profile must be placed firmly on the ground. It's important the ground can't subside. (e.g. sand-cement)



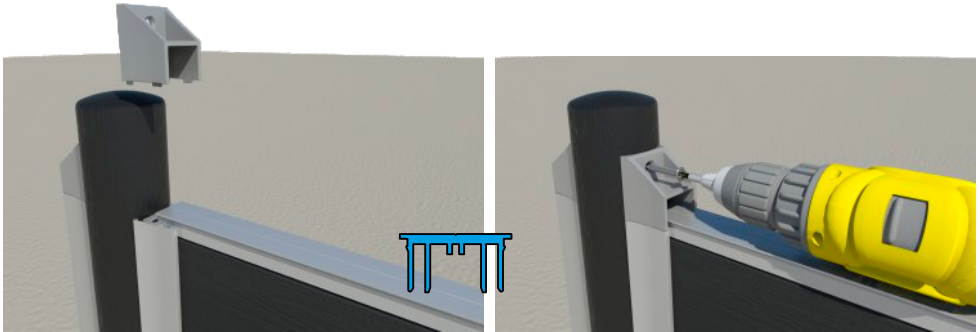
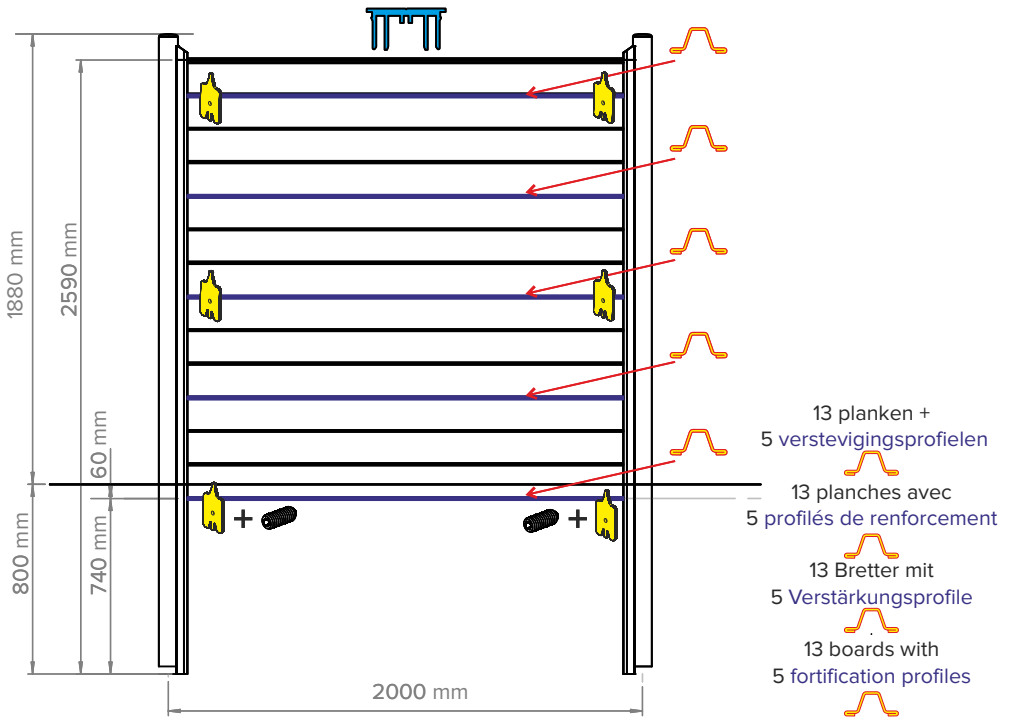

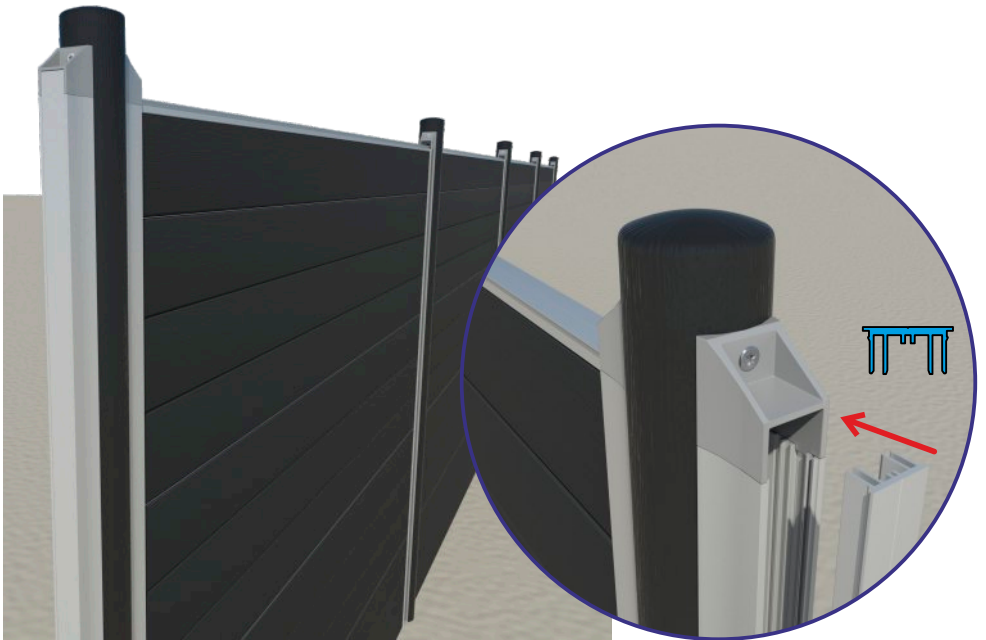
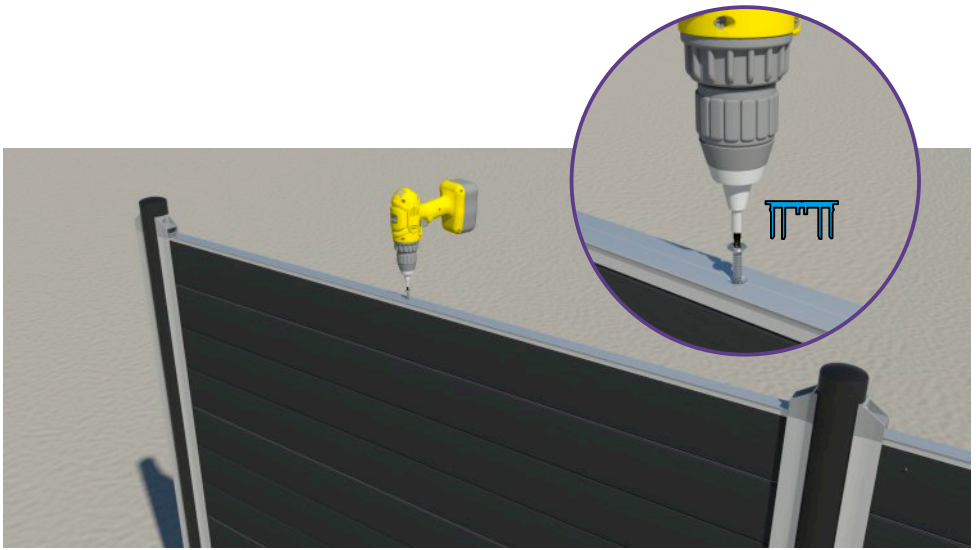

Elke paal, ook elke begin- en eindpaal moet voorzien zijn van 2 U-profielen (1 U-profiel indien bevestigd tegen een muur).

Chaque piquet, aussi le premier et le dernier, doit être pourvu de deux profilés U (1 profilé U si fixé contre un mur).

Jeder Pfosten, auch der erster und letzter, muss mit zwei U Profilen ausgestattet werden (1 U Profil falls gegen einen Wand befestigt).

Each post, also the first and the last one, must be equipped with two U-profiles (only 1 U-profile, if fixed to a wall)

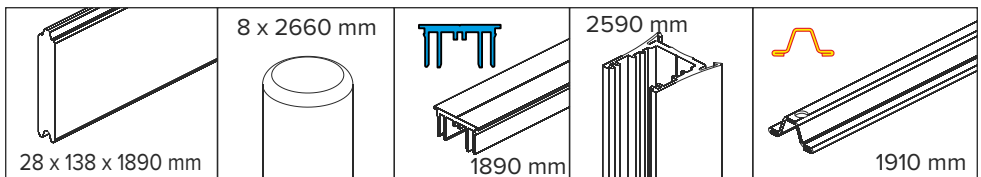
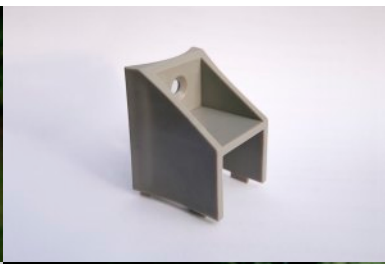

28 x 138 x 1890 mm

8 x 2660 mm

1890 mm

2590 mm

1910 mm

plank  
planche  
Brett  
board

paal  
piquet  
Pfosten  
post

afdekprofiel  
profilé de recouvrement  
Abdeckprofil  
cover profile

U-profiel  
profilé U  
U-Profil  
U-profile

versterkingsprofiel  
profilé de renforcement  
Verstärkungsprofil  
fortification profile

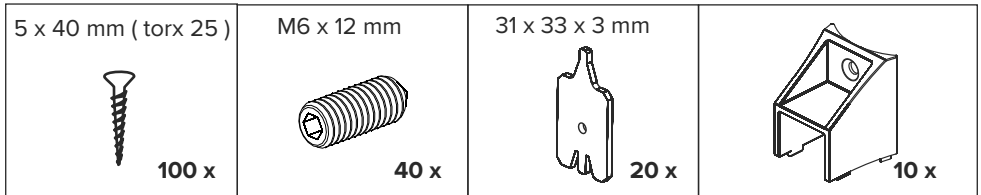

Gova-screw

Gova-set-screw

Gova-clip

Gova-Cap

**GOVA<sup>®</sup>home+**  
**PLAST**

variant : scherm 2m hoog  
 variante: hauteur palissade 2m  
 Variante : Wand 2 m hoch  
 alternative : 2m high fence

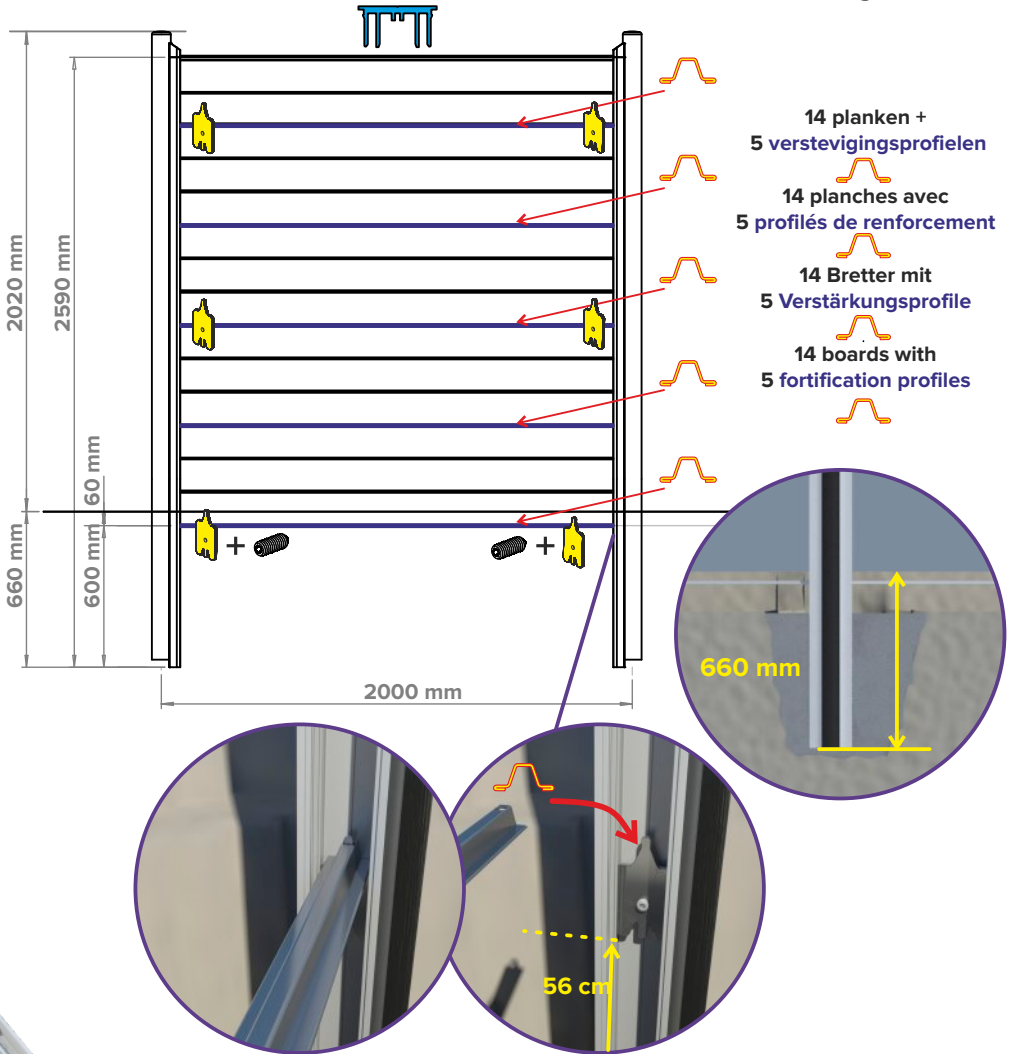

**Tip :** extra verankering met draadstang door paal  
 (+/- 40 cm van de onderkant paal)

**Conseil :** ancrage supplémentaire avec tige à travers le piquet  
 (à +/- 40 cm du bas du piquet)

**Tipp:** extra Verankerung mit Stange durch Pfosten  
 (+/- 40 cm von der Unterseite des Pfostens)

**Tip:** extra anchorage using bar through post  
 (+/- 40 cm from the bottom of the post)